

SECTION 6 - DRIVE SYSTEM

TABLE OF CONTENTS

Drive System.....	6-2
General Information.....	6-2
Rear Suspension/Rear Drive	
Assembly Schematics	6-3
Front Drive Actuator	6-4
Front Differential	6-5
Drive Axles	6-18
Rear Gear Case	6-23
Hub.....	6-24
Hydraulic Brake Caliper.....	6-26
Hydraulic Brake Assembly Schematic.....	6-27



Drive System

■ **NOTE:** Some photographs and illustrations used in this section are used for clarity purposes only and are not designed to depict actual conditions.

General Information

All gear cases are tagged beneath a cover bolt. This tag is marked with a production date code, sequence code, and a ratio code.

A “6” on the lower-right corner indicates a 3.6:1 gear set ratio (10:36 teeth).

The die-cast aluminum housings have been assembled with thread-rolling screws (trilobular). When assembling with these screws, start the screws carefully into the housing; then use the following torque values.

Size	New Housing	Reassembled Housing
M6 (Torx T-30 Recess)	1.1-1.3 kg-m (8-9.5 ft-lb)	0.9-1.2 kg-m (6.5-9 ft-lb)
M8 (Torx T-40 Recess)	3.5-4.3 kg-m (25-31 ft-lb)	2.9-3.5 kg-m (21-25 ft-lb)
M10 (Torx T-50 Recess)	5.1-6.3 kg-m (37-45.5 ft-lb)	4.3-5.3 kg-m (31-38 ft-lb)

SPECIFICATIONS

Specific specifications regarding the the gear cases (capacities, lubricant type, etc.) can be found in Section 1 of this manual.

Ring Gear Backlash	0.28-0.38 mm (0.011-0.015 in.)
Ring Gear End Play	0.1-0.2 mm (0.004-0.008 in.)

SPECIAL TOOLS

A number of special tools must be available to the technician when servicing the gear case.

Description	p/n
Boot Clamp Pliers	0444-120
Pinion Gear/Shaft Removal Tool	0444-127
Slide Hammer w/CV Joint Attachment	0444-123
CV Joint Attachment (Only)	0444-119
Internal Hex Socket (48 mm)	0444-104

■ **NOTE:** Special tools are available from the Arctic Cat Service Parts Department.

TROUBLESHOOTING

If a noise is heard from the gear case area, it can be difficult to locate and/or diagnose. If the noise is related to wheel speed, but not to engine RPM, the problem is probably in the final drive or engine/transmission bevel gear set. When a problem is localized, a number of inspections must be made to pinpoint that problem. The most obvious of the inspections include CV boots, wheel and hub nut tightness, wheel bearing damage, gear case lubricant contamination, low lubricant level, seal leakage at the input shaft, CV joints, or selector arm.

■ **NOTE:** Small metallic particles will collect on the magnetic drain plug as a normal part of break-in and will also give a metallic cast to drained lubricant. Contamination would include large particles or water which gives a “milky” look to the lubricant.

■ **NOTE:** Lubricant on a new pinion housing assembly could be grease. If the front of the gear case is leaking at the rear drive boot, wipe excess lubricant from the bottom of the pinion housing; then operate the ATV for a period of time. Inspect the pinion housing area for any signs of leakage. If lubricant is again on the bottom of the pinion housing, the seal must be replaced.

Additional troubleshooting could include the following.

- Binding/abrupt motion: CV boot torn (grease loss, foreign object damage, broken cage); gear lubricant loss or not filled (bearing seizure, broken gear teeth, seal leakage, bladder or hose leakage, missing filler/drain plug).
- Noise from drive system: wheel or gear case bearing damage, improper gear backlash, improper assembly, low or no gear case lubricant.
- Lockup: gear case lubricant loss or not filled, water contamination causing bearing seizure.

Rear Suspension/Rear Drive Assembly Schematics

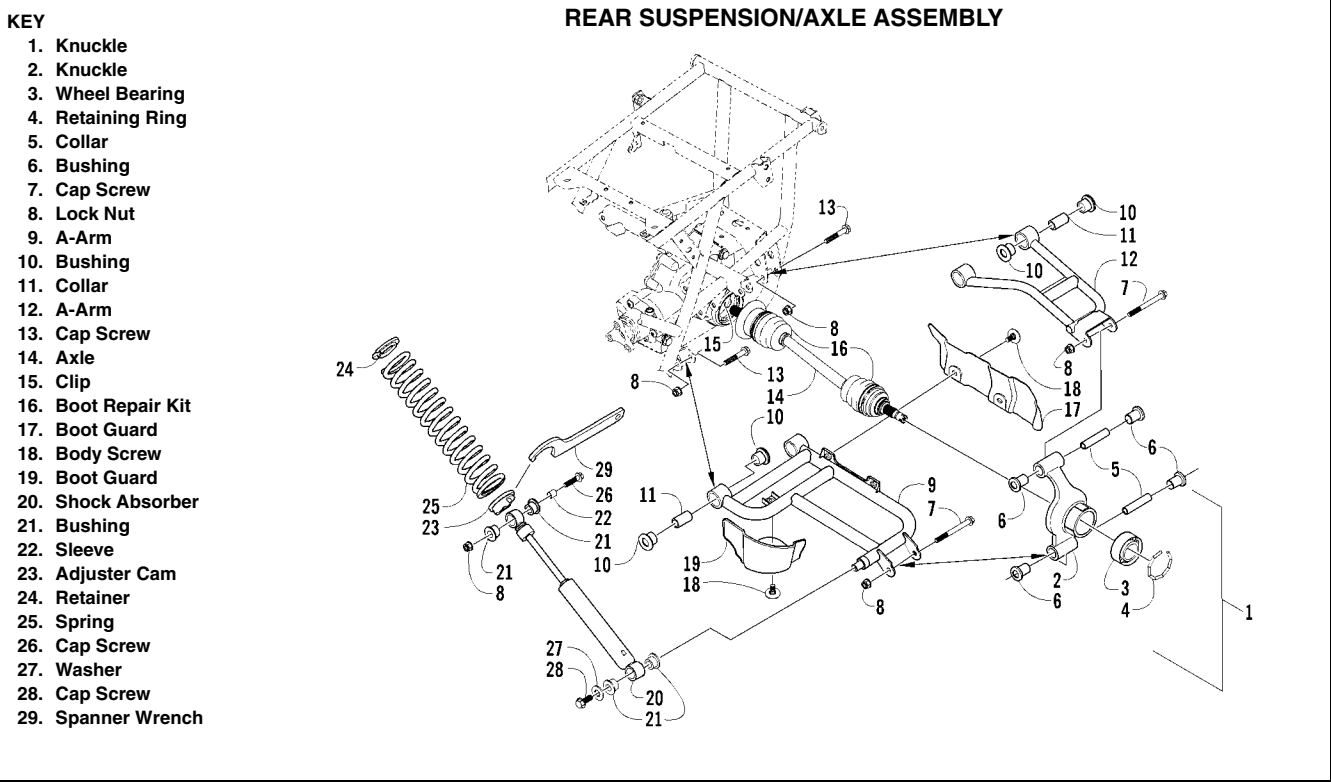

0739-056

6

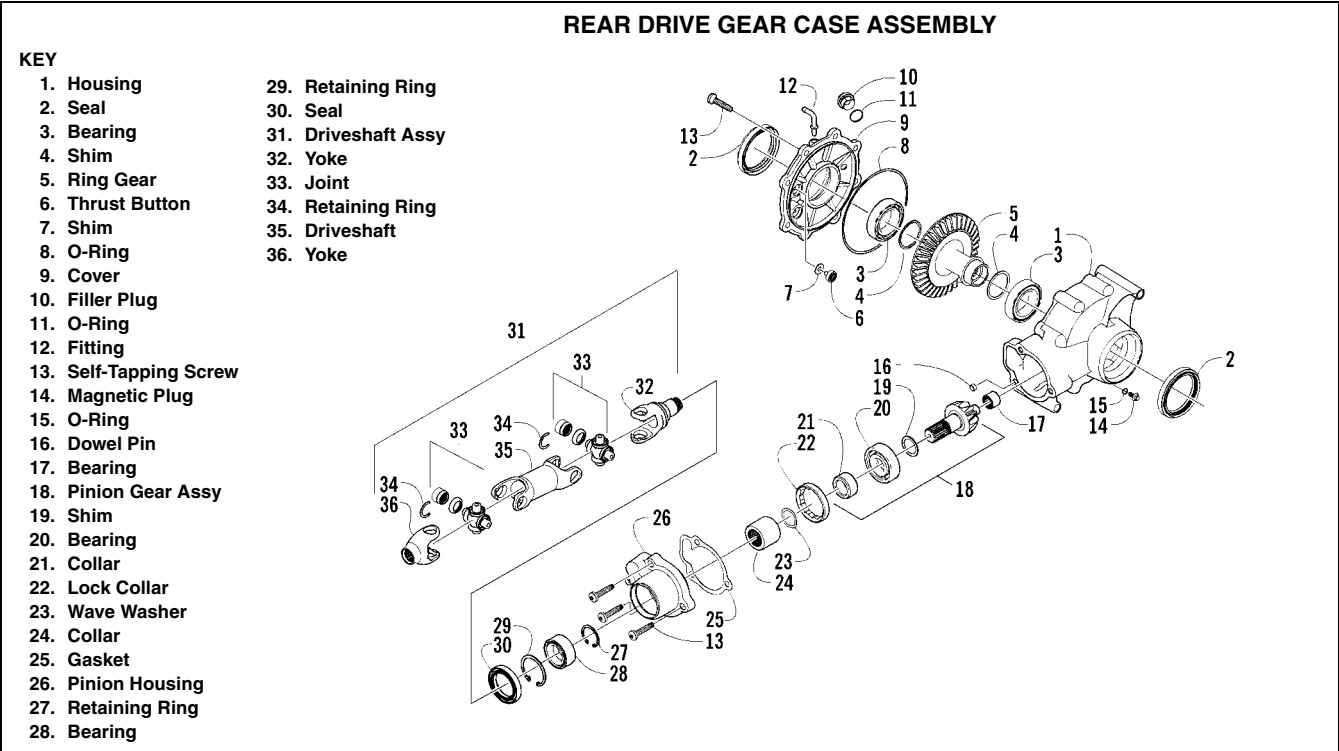

0739-145

[Back to Table of Contents](#)

[Back to Section TOC](#)

Front Drive Actuator

■ **NOTE:** The actuator is not a serviceable component. If it is defective, it must be replaced.

■ **NOTE:** The actuator will operate only when the ignition switch is in the ON position.

The front drive actuator is located on the left side of the front drive input housing. With the engine stopped and the ignition switch in the ON position, a momentary “whirring” sound can be heard each time the front drive selector switch is shifted. If no sound is heard, see Section 5. If the actuator runs constantly or makes squealing or grinding sounds, the actuator must be replaced.

REMOVING

1. Remove the left-front inner fender panel; then disconnect the three-prong connector on the actuator harness.
2. Using a T-30 torx wrench, remove the mounting cap screw from the driveshaft side of the actuator.



AG926

3. Remove the mounting cap screw from below the actuator on the suspension side.



AG927

4. Loosen but do not remove the mounting cap screw at the front of the actuator; then slide the actuator to the rear enough to clear the slotted mounting tab and the selector shaft. Account for an O-ring.

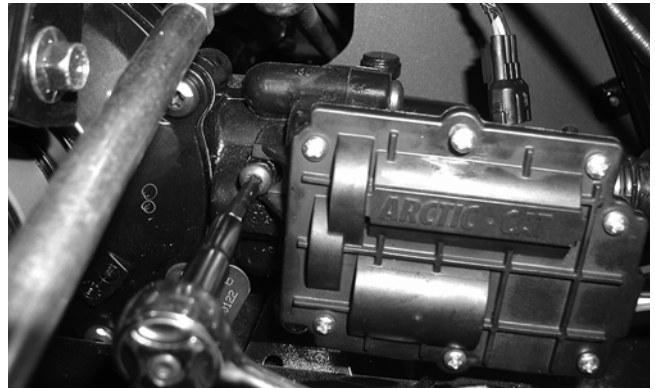

AG928

INSTALLING

1. Ensure that all mounting surfaces are clean and free of debris.

■ **NOTE:** Apply Arctic Cat ATV High-Performance Grease (p/n 0436-501) to the O-ring surface.

2. Place the O-ring into position; then align the actuator with the selector shaft and slide it forward onto the shaft taking care to engage the cap screw in the slot of the front mounting tab.



AG925

3. While holding the actuator firmly forward, tighten the front cap screw to hold the actuator in place; then install but do not tighten the two remaining cap screws.

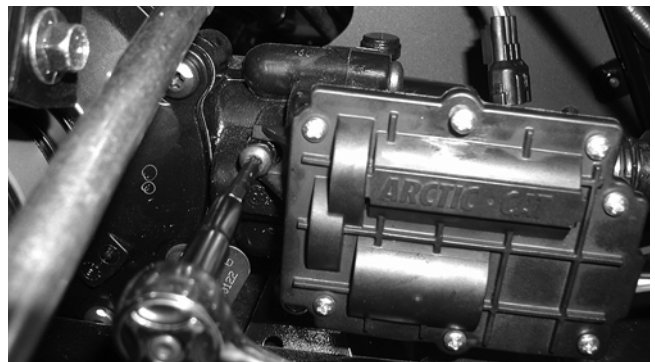

AG928

- Loosen the front cap screw; then tighten the cap screw on the driveshaft side.



AG926

■ **NOTE:** It is important to tighten this cap screw while the others are loose to ensure proper seating of the actuator.

- Tighten the remaining cap screws; then connect the electrical plug to the main harness.
- Turn the ignition switch to the ON position and check the operation by shifting the selector switch several times.
- Secure the wiring harness to the frame with a nylon cable tie; then install the inner fender panel.

■ **NOTE:** Make sure that the wiring harness is clear of the exhaust pipe and left-side tie rod.

Front Differential

■ **NOTE:** To remove the rear gear case, see Rear Gear Case in this section.

REMOVING DIFFERENTIAL

- Secure the ATV on a support stand to elevate the wheels.

⚠ WARNING

Make sure the ATV is solidly supported on the support stand to avoid injury.

- Remove the filler plug and the drain plug and drain the gear lubricant into a drain pan; then reinstall the plugs.
- Remove the front wheels.

- Pump up the hand brake; then engage the brake lever lock.
- Remove the cotter pin securing the hex nut; then remove the hex nut and washer. Release the brake lever lock.

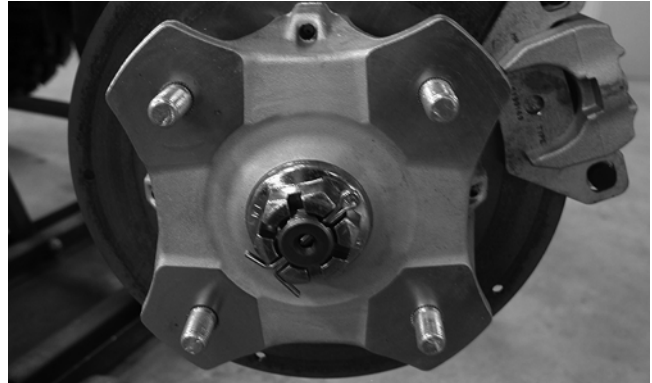

KX041

■ **NOTE:** It is not necessary to remove the brake hoses from the calipers for this procedure.

- Remove the brake calipers. Account for the cap screws.

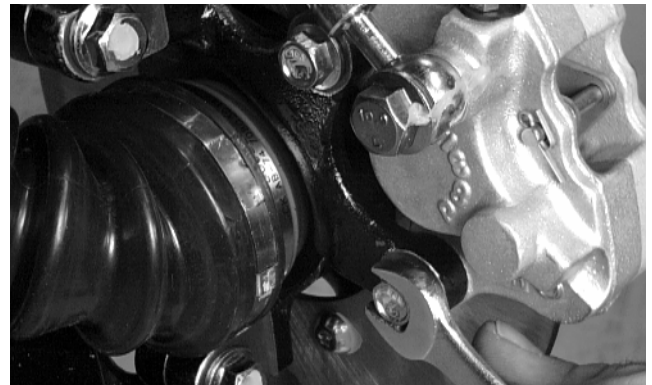

AF894D

- Remove the tie rod cotter pins and discard the pins.



AF895D

- Remove the tie rod lock nuts.



AF896D

9. Remove the upper ball joint cap screws taking care not to strip the threads on the ball joint shaft; then using a rubber mallet, tap the end of the axle and free it from the knuckle assembly.

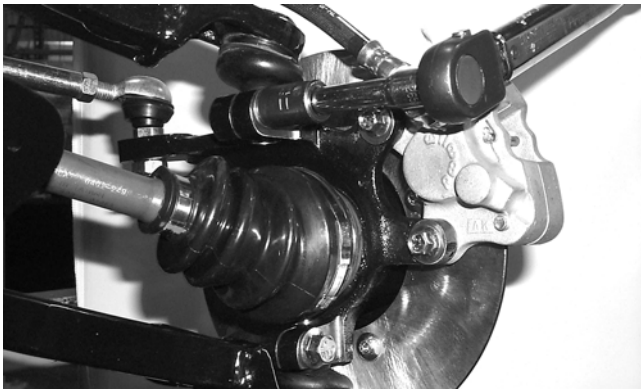

AF628D

10. Pull the steering knuckle away from the axle taking care not to damage the seals with the axle end.



KX151

11. Support the axle to not allow it to drop or hang.

⚠ CAUTION

The axle must be supported. If the axle is allowed to drop or hang, damage to the inner CV joint may occur.

12. Remove the lower shock bolts. Account for the lock nuts; then move the shocks aside and secure them with a strap.



AF897D

13. Remove the upper A-arm lock nuts and cap screws; then remove the A-arms.

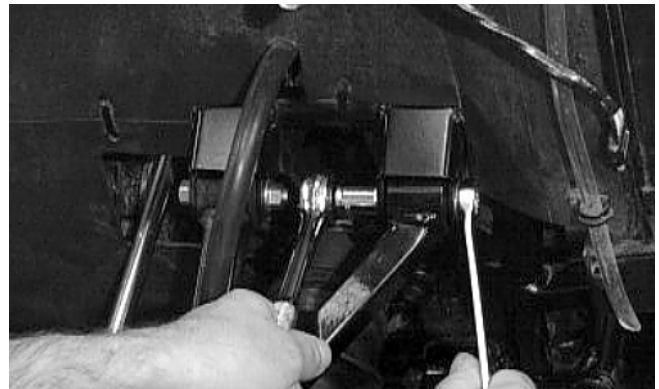

AF610D

14. Using a slide hammer, remove the front axles.



AF899D

15. Remove the inner fender panels; then loosen the clamp on the front air duct and move the duct aside.

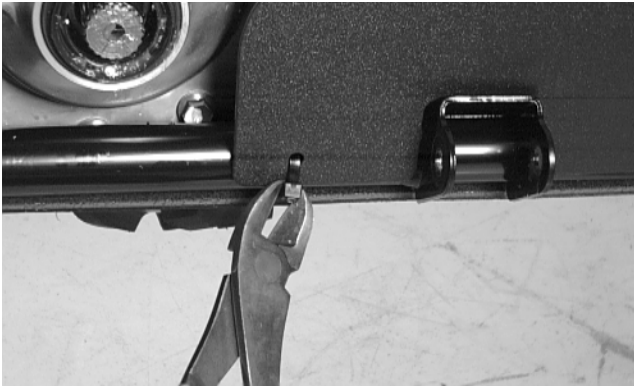

AF902D

■ **NOTE:** To remove the panels, there will be a torx-head screw and three cable ties per side.

- Using a T-30 torx wrench, remove the three screws securing the front drive actuator to the gear case; then remove the actuator (see Front Drive Actuator in this section).



AG925

- Remove the lower differential mounting bolt. Account for a lock nut and washers.

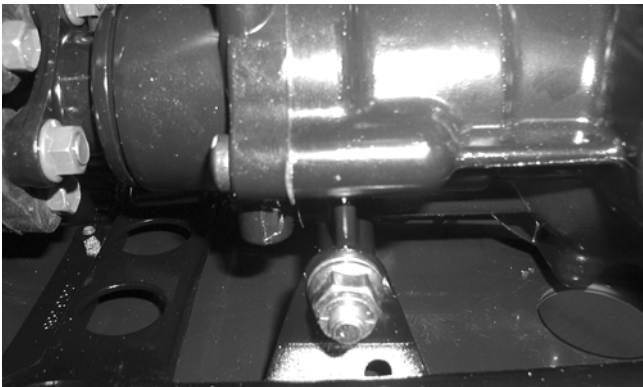

CD026

- Remove the upper differential mounting bolt. Account for a lock nut and washers.



CD016

- Free the differential assembly from the frame mountings; then shift the assembly forward in the frame sufficiently to disengage the splines of the driveshaft from the engine.



KX161

- Lay the differential on right side; then maneuver it out of the frame with the driveshaft attached.



KX159

Disassembling Input Shaft Housing

■ **NOTE:** This procedure can be performed on a rear gear case.

- Using a T-40 torx wrench, remove the cap screws securing the input shaft housing cover.
- Using a rubber mallet, remove the cover. Account for a gasket. Remove the fork, collar, and spring. Note the location of all the components for assembling purposes.

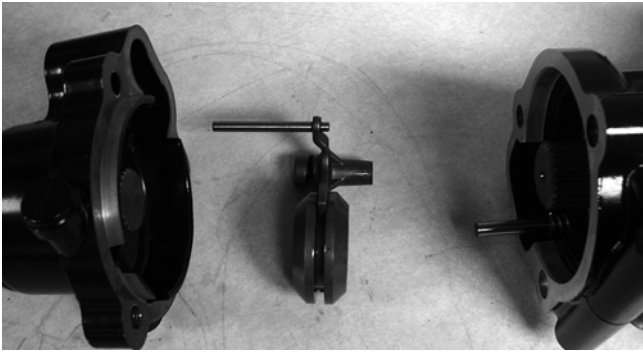

CD106

3. Remove the circlip; then remove the input shaft from the housing.

■ **NOTE:** The input shaft-to-bearing clearance is a hand-press fit. A light tap with a rubber mallet may be necessary to remove the shaft from the bearing.

4. Remove the input shaft from the housing.

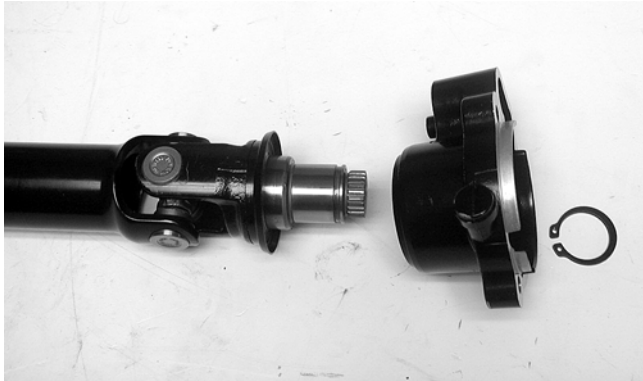

KX210

5. Using a seal removal tool, remove the input shaft seal.



KX218

6. Remove the snap ring securing the input shaft bearing; then place the input shaft housing in a press and remove the bearing.



KX219

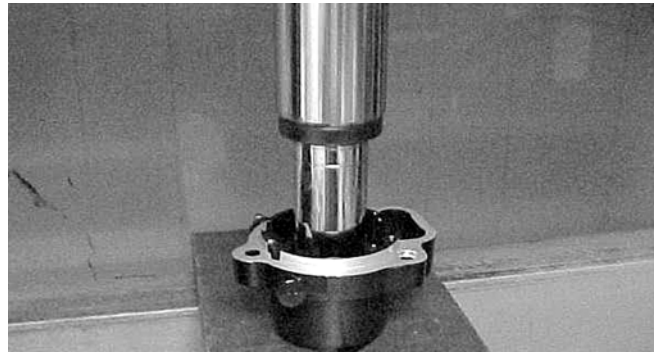

AF984

Assembling Input Shaft Housing

1. Place the input shaft housing in a press and install the input shaft bearing. Secure the bearing with the existing snap ring making sure the sharp edge of the snap ring faces to the outside.

CAUTION
Care must be taken to press on the outside race only or bearing damage will occur.



KX220



AF994

2. Install the input shaft seal making sure it is flush with the edge of the housing.



KX221



KX222

3. Install the input shaft into the housing; then secure it in the bearing with the circlip.



KX210

4. Place the input shaft assembly with a new gasket onto the gear housing; then secure with the existing cap screws. Tighten to 2.9-3.5 kg-m (21-25 ft-lb).

■ **NOTE:** If a new gear housing is being installed, tighten the cap screws to 3.5-4.3 kg-m (25-31 ft-lb).

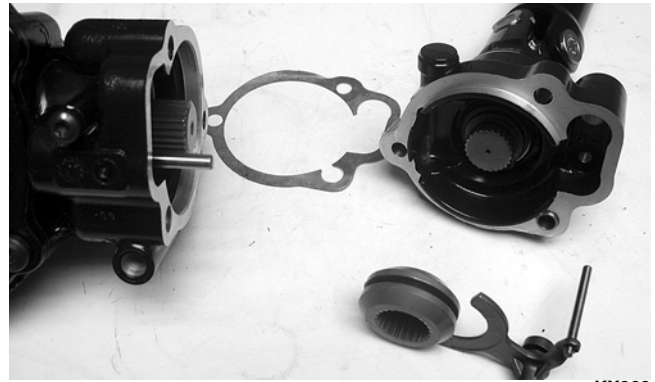

KX209



KX158

Disassembling Pinion Gear

■ **NOTE:** This procedure can be performed on a rear gear case.

1. Using a T-40 torx wrench, remove the cap screws securing the input assembly. Account for the coupler, fork, and spring.



KX209

2. Using a T-40 torx wrench, remove the cap screws securing the differential cover. Account for and make note of the ID tag location for assembling purposes.

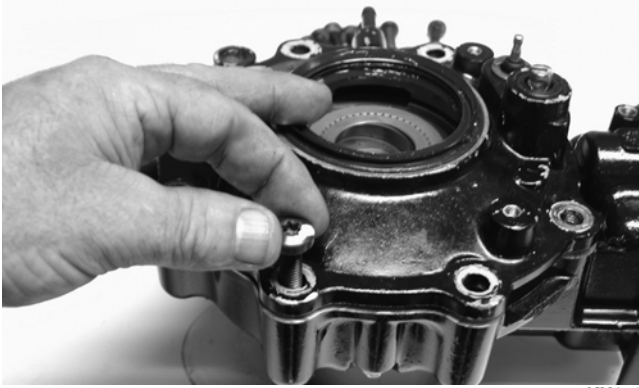

KX173

3. Using a plastic mallet, tap lightly to remove the differential cover. Account for an O-ring.

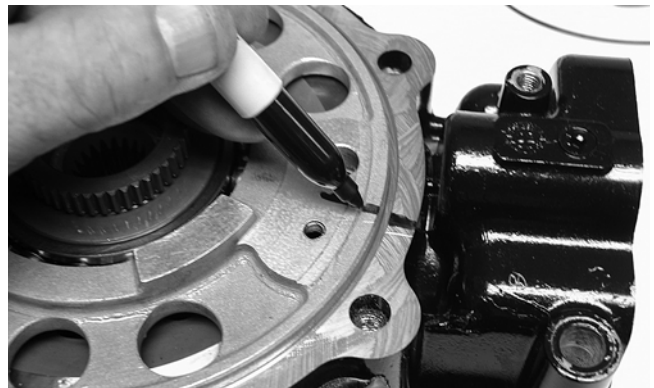

KX176



KX174

■ **NOTE:** If the cover is difficult to remove, pry on the cover in more than one recessed location.

4. Remove the splined coupler, shifter fork, pin, and spring of the differential lock assembly and set aside. Note position of parts for assembling purposes.



KX177



KX178



KX175

5. Make match marks on the left bearing housing and differential housing; then remove the plate and account for a shim. Mark the shim as left-side.

6. Place the differential with the open side down; then lift the housing off the spider assembly. Account for shim(s) and mark as right-side.



KX179



KX181

7. Using the 48 mm Internal Hex Socket (p/n 0444-104), remove the nut securing the pinion gear assembly.

■ **NOTE:** On a front differential, the nut has right-hand threads. On a rear gear case, the nut has left-hand threads.

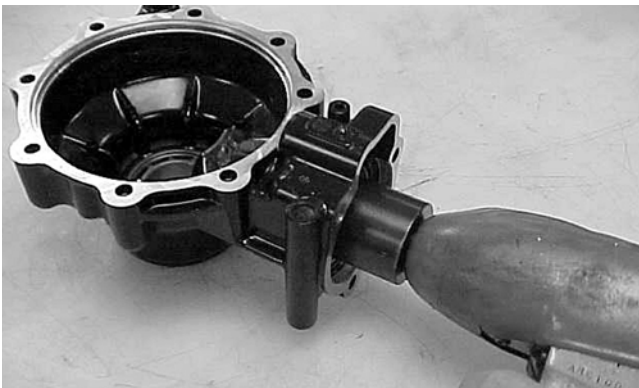

CC875



CC876

8. Using the Pinion Gear/Shaft Removal Tool (p/n 0444-127) and a hammer, remove the pinion gear from the housing.

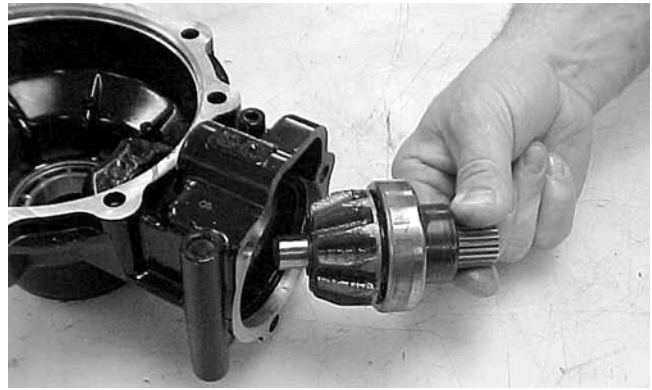

CC878

9. Secure the pinion gear in a bearing puller; then remove the pinion bearing using a press. Account for a collar, a bearing, and a shim.

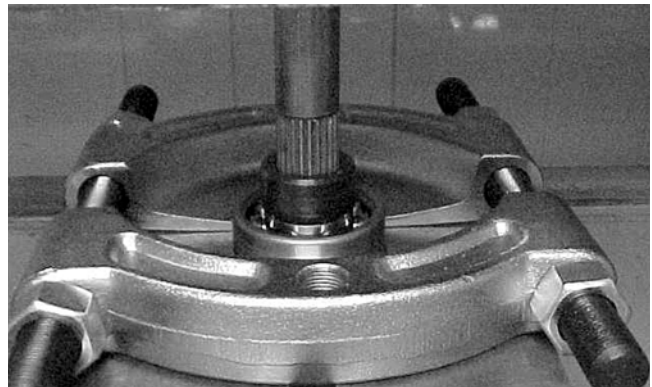

CC879



CC880

■ **NOTE:** If gears are being replaced, use the existing shims. The numbers are scribed onto the gears: the ring gear has the number on the opposite side of the gears, and the pinion gear has the number on the end of the pinion gear shaft by the splines. If no number is present, it should be considered as being in the O category.

■ **NOTE:** If the housing is being replaced, proceed to the following Shimming Procedure/Shim Selection sub-section.

6

Shimming Procedure/Shim Selection

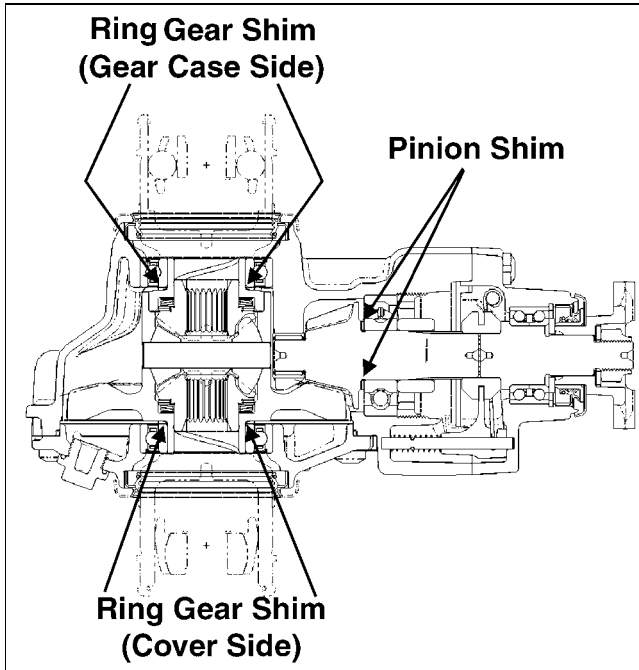

502-119A

1. Press bearings into bores by outer ring to hard contact with seat.
2. Note the following shim selections (shims are nominally 1.5 mm/0.060 in. thick):
 - A. Pinion Gear Sub-Assembly - add the value (A) on the gear case housing with 1.5 mm (0.060 in.); then subtract the value on the 10-tooth pinion gear. This will give you the proper shim thickness.
 - B. Cover Side - add the value (B) on the gear case housing to the value (C) on the gear case cover; then add 1.5 mm (0.060 in.). This will give you the proper shim thickness.
 - C. Gear Case Side - install a 1.3-1.4 mm (0.050-0.055 in.) shim and tighten the bolts to 3.5-4.3 kg-m (25-31 ft-lb). Verify backlash to be within a range of 0.28-0.38 mm (0.011-0.015 in.) and end-play to be within a range of 0.10-0.20 mm (0.004-0.008 in.). If not within specification range, reselect shim until backlash specification range can be verified.

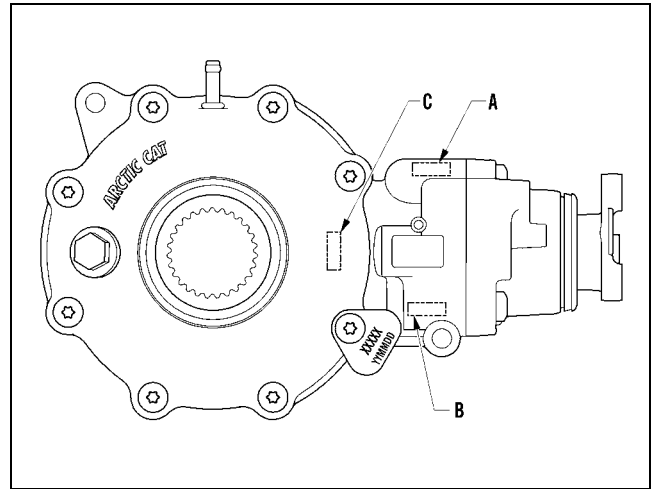

738-268A

3. Apply molybdenum disulfide grease to all oil seal lips.
4. Prelubricate journal on pinion assembly with SAE 80W-90 hypoid gear lubricant prior to pressing assembly into gear case housing.
5. Tighten lock collar to 16.6 kg-m (120 ft-lb) and deform/lock edge approximately 1.5 mm (0.060 in.) into lower oil channel.

Assembling Pinion Gear

1. Place the shim (with the chamfer side toward the inside) onto the pinion shaft; then install the bearing onto the pinion shaft. Install the pinion shaft collar.

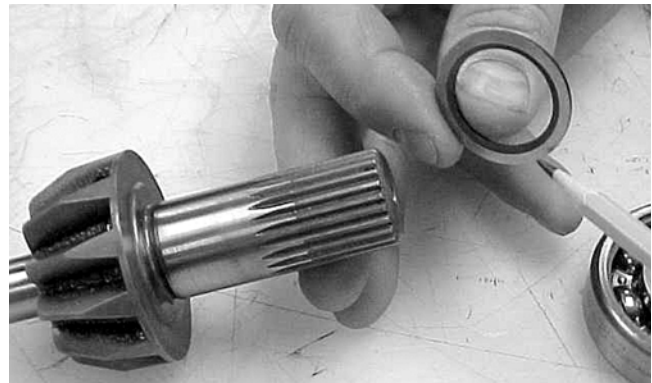

CC881

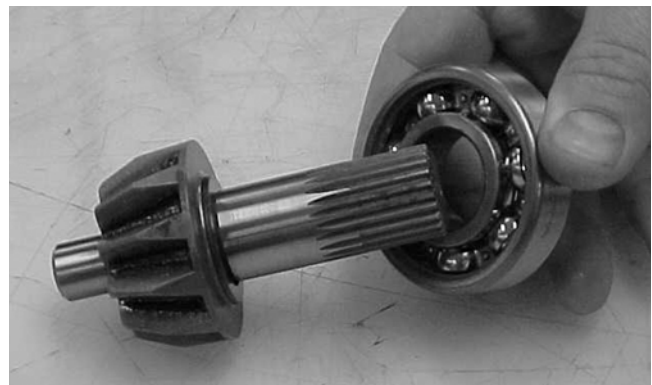

CC882

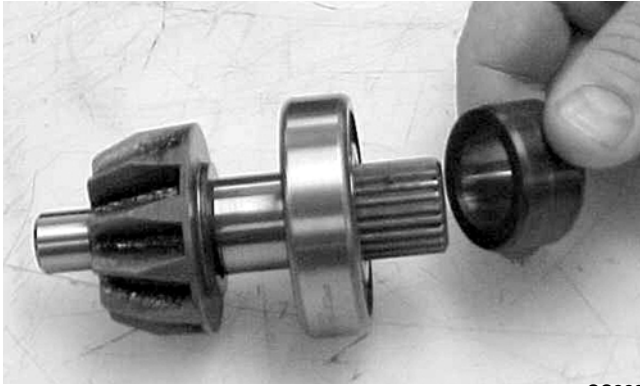

CC883

- Place the pinion assembly in a bearing puller; then install the bearing using a press.

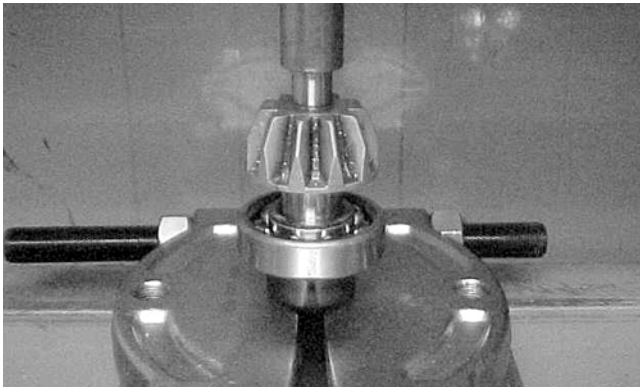

CC884

- Install the pinion gear assembly into the housing. Using the 48 mm Internal Hex Socket (p/n 0444-104), secure the pinion gear assembly with the existing nut. Tighten to 17.5 kg-m (125 ft-lb).

■ **NOTE:** On a front differential, the nut has right-hand threads. On a rear gear case, the nut has left-hand threads.

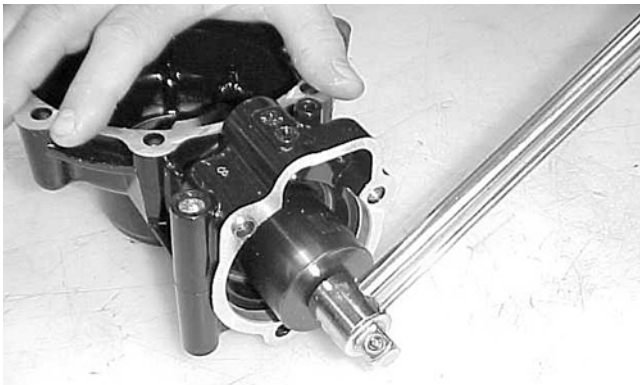

CC890

- Place a punch on the edge of the nut in the oil gallery area; then using a hammer, stake the nut to ensure that the nut will remain securely tightened.

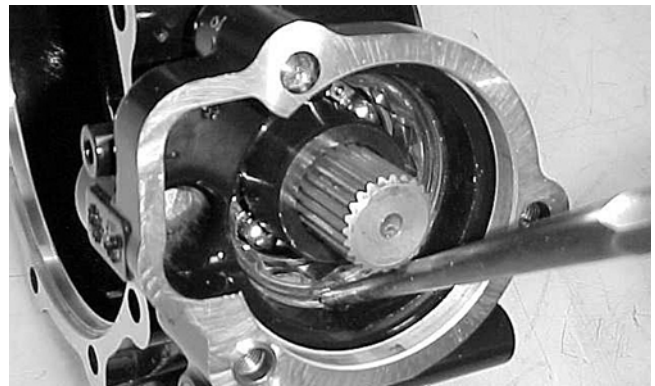

CC891

- Install the shift fork shaft w/spring into the gear housing making sure the shaft O-ring is positioned to the inside.

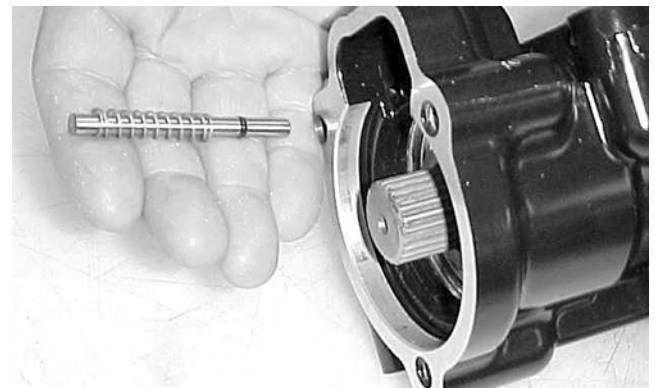

CC892

- Install the shift fork assembly making sure the fork leg is facing upward. Apply a small amount of oil to the gasket; then install the gasket.

6

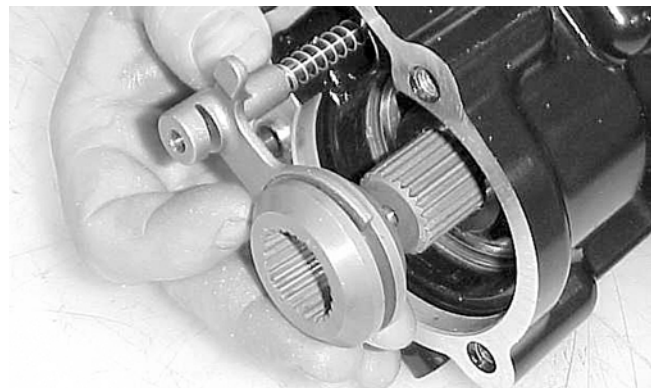

CC893

- Place the input shaft assembly onto the gear housing; then secure with the existing cap screws. Tighten to 2.9-3.5 kg-m (21-25 ft-lb).

■ **NOTE:** If a new gear housing is being installed, tighten the cap screws to 3.5-4.3 kg-m (25-31 ft-lb).

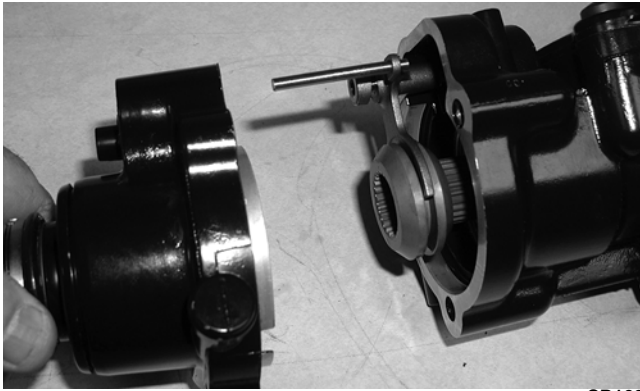

CD103

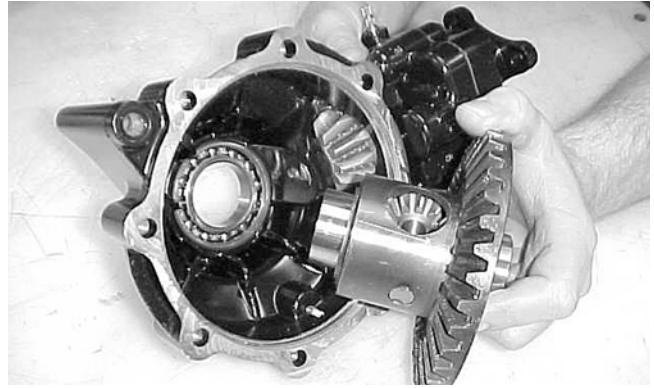

CC897



CD110



KX178

8. Install the proper shim onto the ring gear spider assembly making sure the chamfer side of the shim is facing toward the ring gear. Install the ring gear in the housing; then install the outside shim with the chamfer side of the shim toward the ring gear.

■ **NOTE:** The spider and ring gear assembly must be replaced as a complete unit.

9. Install the left bearing housing aligning the match mark to the mark on the differential housing.

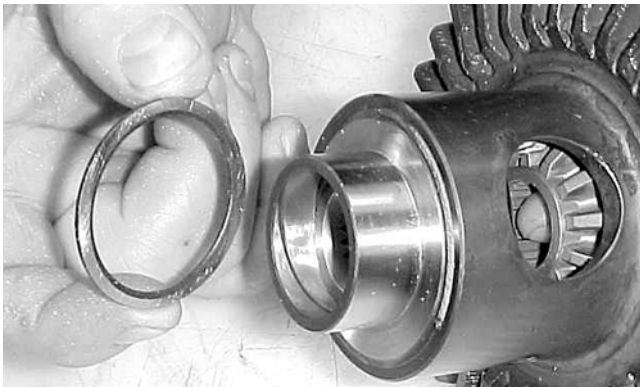

CC896



KX177

10. Install the differential lock assembly into the bearing housing; then place the O-ring on the differential housing.

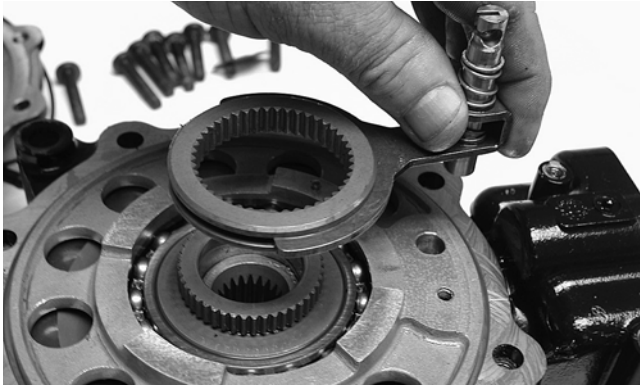

KX175



KX174

11. Making sure the O-ring is properly positioned on the differential cover, install the differential cover with existing hardware. Account for the ID tag. Tighten the cap screws to 2.9-3.5 kg-m (21-25 ft-lb).

■ **NOTE:** Grease can be applied to the O-ring for ease of assembling.

■ **NOTE:** If a new gear housing is being installed, tighten the cap screws to 3.5-4.3 kg-m (25-31 ft-lb).

Removing Needle Bearing

■ **NOTE:** Removing the needle bearing is rarely necessary. Avoid removing the needle bearing unless the bearing is clearly damaged.

■ **NOTE:** This procedure can be performed on a rear gear case.

1. Place a 6.35 mm (1/4 in.) drill bit on the inside surface of the needle bearing (against the bottom side); then drill through the pinion shaft needle bearing housing.

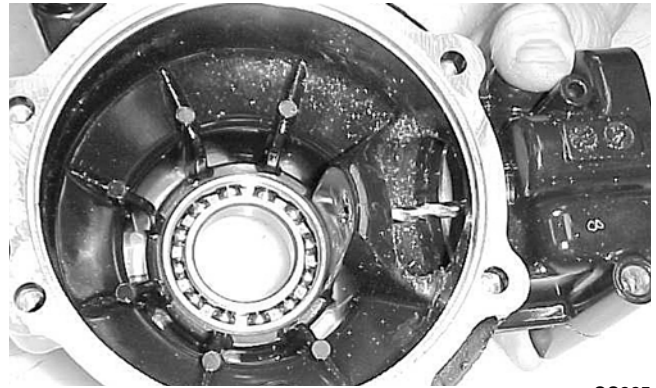

CC885

2. Using a propane torch, heat the area surrounding the needle bearing to approximately 300°.

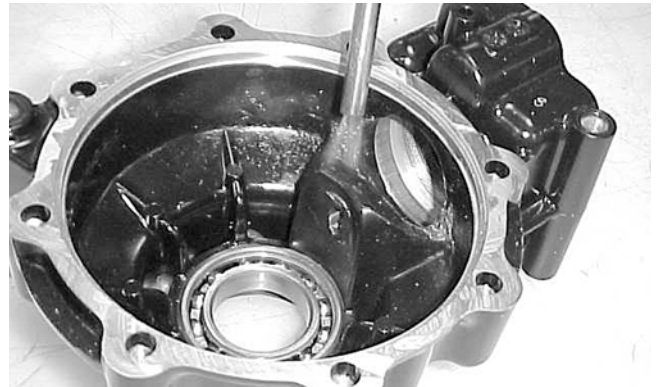

CC886

3. Using a flat-nosed punch, drive the bearing out of the housing.



CC887

Installing Needle Bearing

1. Place the new bearing into the housing.

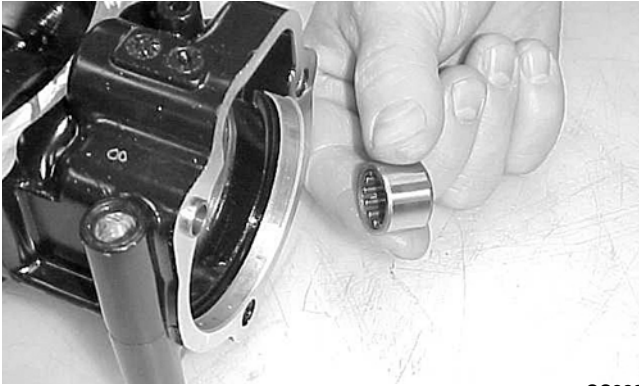

CC888

- Using a suitable driver, install the needle bearing into the housing making sure the bearing is seated.

■ **NOTE:** Do not push the bearing too far into the housing.

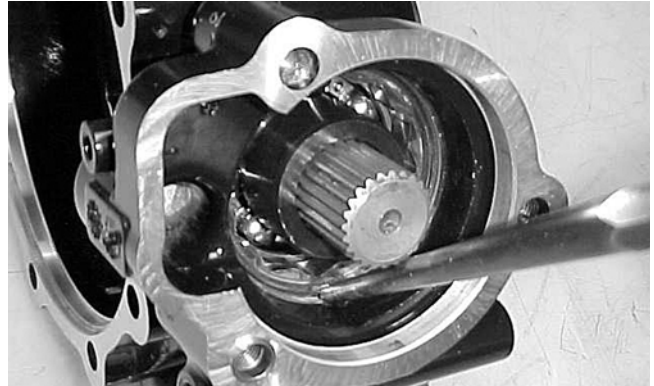

CC891

- Install the input shaft housing.

Removing/Installing Axle Seal

■ **NOTE:** This procedure can be performed on a rear gear case.

- Remove the seal using a seal removal tool.

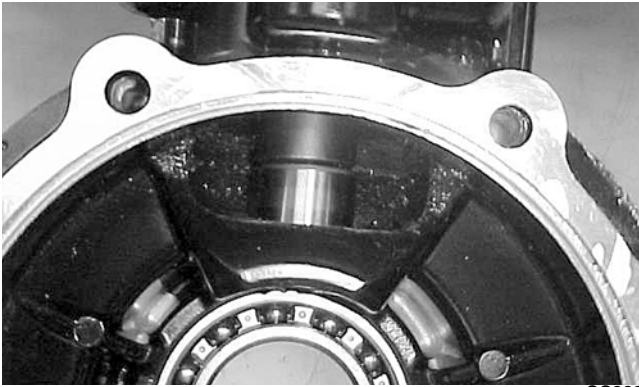

CC889

- Install the pinion shaft and secure with the existing 48 mm nut. Tighten to 17.5 kg-m (125 ft-lb).

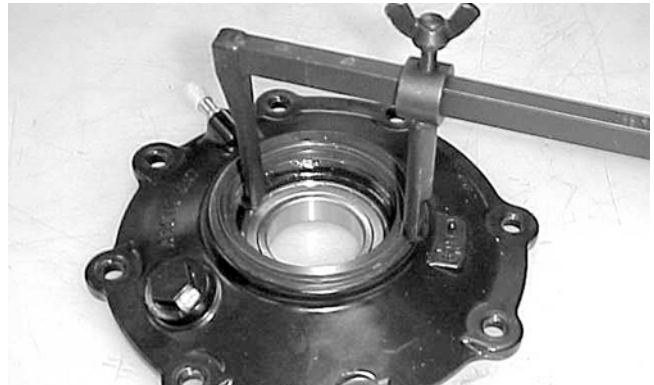

CC899

- Using a press, remove the bearing.

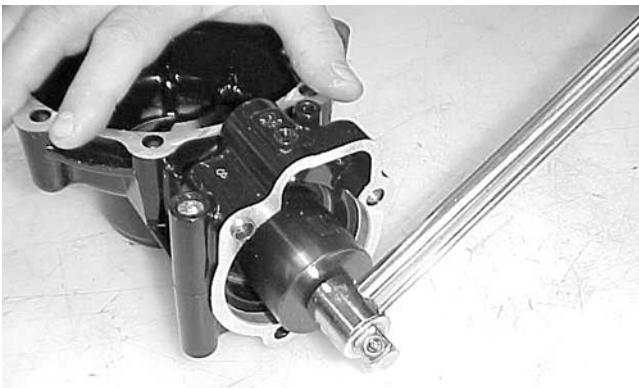

CC890

- Place a punch on the edge of the nut in the oil gallery area; then using a hammer, stake the nut to ensure that the nut will remain securely tightened.



CC900

- Using a press, install the new axle bearing into the housing.

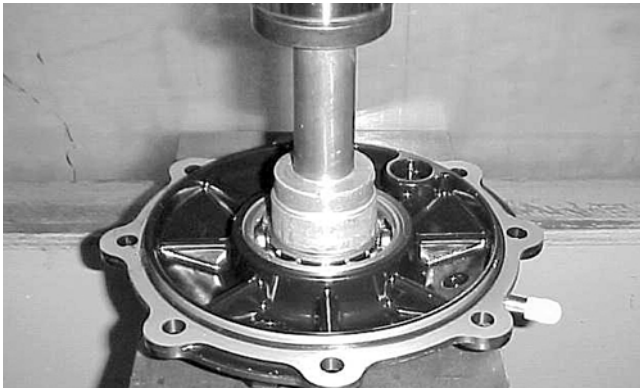

CC901

■ **NOTE:** Prior to installing the seal, apply grease to the seal outside diameter.

4. Install the seal into the housing pressing evenly on the outside edge until the seal is seated.

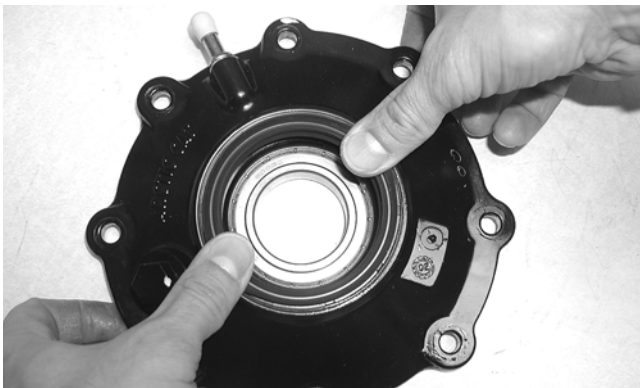

CD018

5. Repeat steps 1-4 for the opposite side.

INSTALLING DIFFERENTIAL

1. Align the splined input yoke with the front output splines; then place the differential into position on the frame and install the cap screws, washers, and flex-lock nuts. Tighten to 6.2 kg-m (45 ft-lb). Make sure the rubber boot is properly seated on the input yoke.



KX161



AF905D



AF904D

2. Pour 275 ml (9.3 fl oz) of SAE 80W-90 hypoid lubricant into the differential and install the filler plug. Tighten to 2.2 kg-m (16 ft-lb).
3. Install the front drive actuator and tighten the screws securely; then connect the lead to the main harness.

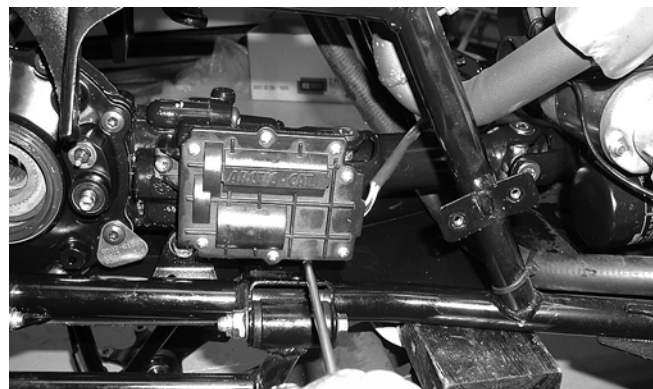

KX164

4. Install the inner fender panels.

■ **NOTE:** To secure the side panels, use a torx-head screw and three cable ties per side.

5. Install the front axles (see Drive Axles in this section).
6. Secure the upper A-arms with cap screws and lock nuts. Tighten to 4.8 kg-m (35 ft-lb).

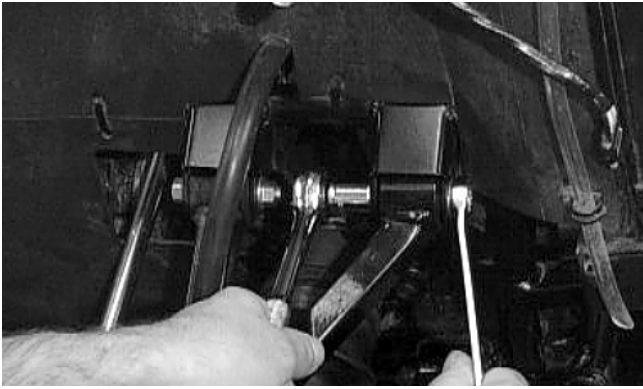

AF610D

7. Secure the lower shock eyelets with cap screws and lock nuts. Tighten to 4.8 kg-m (35 ft-lb).

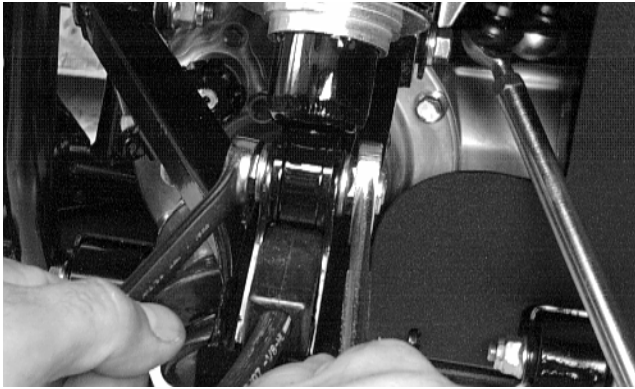

AF897D

8. Secure the tie rods with the lock nuts. Tighten to 4.2 kg-m (30 ft-lb); then install and spread the cotter pins.



AF896D



AF895D

9. Install the brake calipers. Secure with the cap screws tightened to 2.8 kg-m (20 ft-lb).

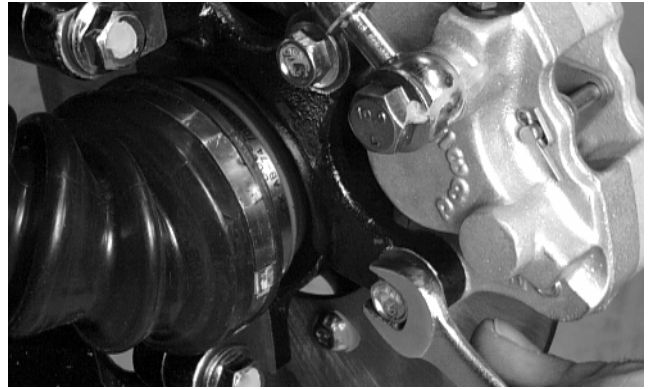

AF894D

10. Install the wheels and tighten to 5.5 kg-m (40 ft-lb).
11. Remove the ATV from the support stand.

Drive Axles

REMOVING REAR DRIVE AXLE

1. Secure the ATV on a support stand to elevate the wheels.

WARNING

Make sure the ATV is solidly supported on the support stand to avoid injury.

2. Pump up the hand brake; then engage the brake lever lock.
3. Remove the wheel.
4. Remove the cotter pin securing the hex nut; then remove the hex nut and rubber washer. Release the brake lever lock.

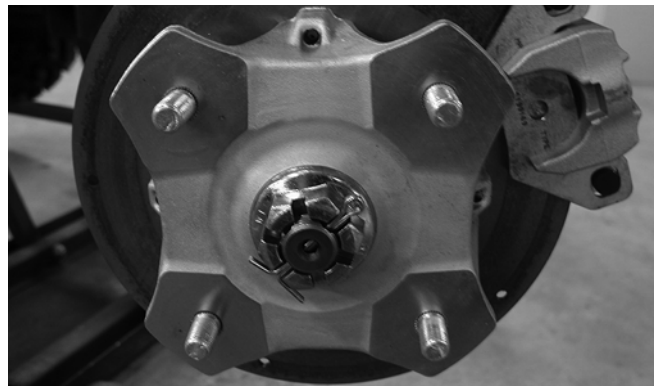

KX041

5. Remove the two brake calipers (right side only).

■ **NOTE:** Do not allow a brake caliper to hang from its hose.

⚠ CAUTION

The calipers should be supported. If the calipers are allowed to hang from the hoses, damage may occur.

6. Slide the hub out of the knuckle and set aside.
7. Remove the cap screw and lock nut securing the knuckle to the upper A-arm. Discard the lock nut.

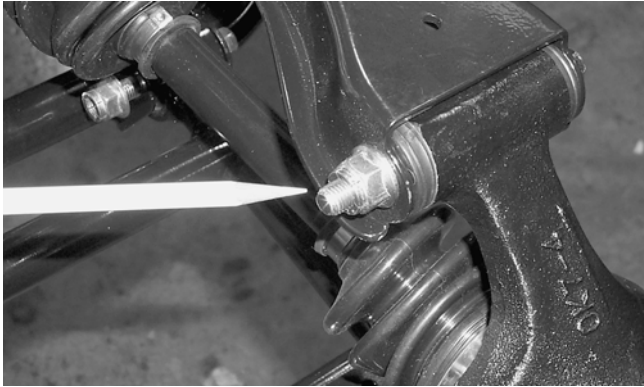

AF936

■ **NOTE:** Never reuse a lock nut. Once a lock nut has been removed, it must be replaced with a new lock nut.

8. While holding the drive axle stationary, pull the top of the knuckle out and down until it is free of the drive axle.
9. Place a drain pan under the ATV to contain any oil leakage; then using a slide hammer, remove the drive axle.



KX184

REMOVING FRONT DRIVE AXLE

1. Secure the ATV on a support stand to elevate the wheels.

⚠ WARNING

Make sure the ATV is solidly supported on the support stand to avoid injury.

2. Pump up the hand brake; then engage the brake lever lock.
3. Remove the wheel.
4. Remove the cotter pin securing the hex nut; then remove the hex nut and washer. Release the brake lever lock.

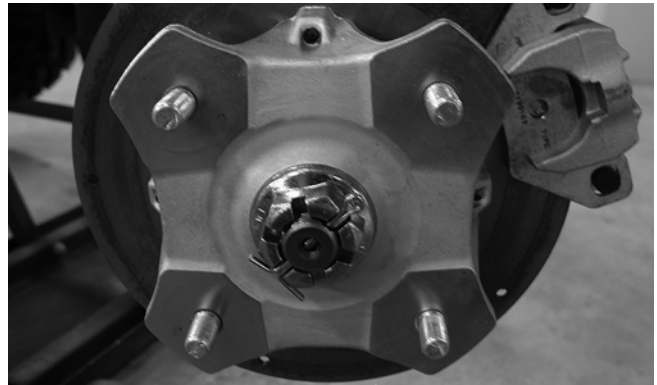

KX041

■ **NOTE:** It is not necessary to remove the brake hose from the caliper for this procedure.

5. Remove the brake caliper.

■ **NOTE:** Support the caliper. Do not allow the caliper to hang from its hose.

⚠ CAUTION

The caliper should be supported. If the caliper is allowed to hang from its hose, damage may occur.

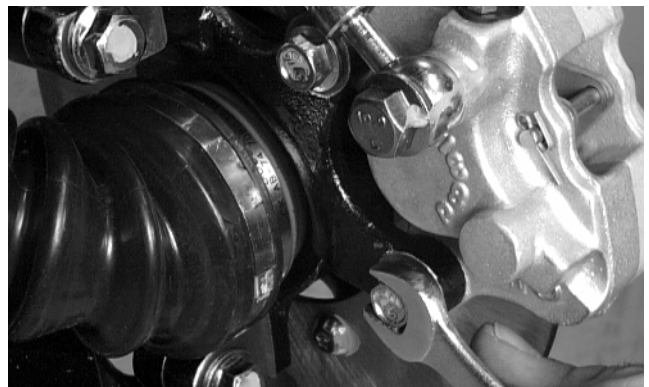

AF894D

6. Slide the hub w/brake disc out of the steering knuckle and set aside.

7. Remove the tie rod from the steering knuckle.



AF896D

8. Remove the cap screw and lock nut securing the lower shock eyelet to the upper A-arm. Discard the lock nut.

■ **NOTE:** Never reuse a lock nut. Once a lock nut has been removed, it must be replaced with a new lock nut.

9. Remove the cap screw securing the upper A-arm ball joint to the steering knuckle; then disengage the ball joint from the knuckle.

10. While holding the drive axle stationary, pull the top of the steering knuckle out and down until it is free of the drive axle.

11. Place a drain pan under the ATV to contain any oil leakage; then using a slide hammer, remove the drive axle.



AF899D

CLEANING AND INSPECTING

■ **NOTE:** Always clean and inspect the drive axle components to determine if any service or replacement is necessary.

1. Using a clean towel, wipe away any oil or grease from the axle components.



CD019

2. Inspect boots for any tears, cracks, or deterioration.

■ **NOTE:** If a boot is damaged in any way, it must be replaced with a boot kit.

DISASSEMBLING AXLES

1. Using a side-cutters (or suitable substitute), remove the large clamp from the boot.

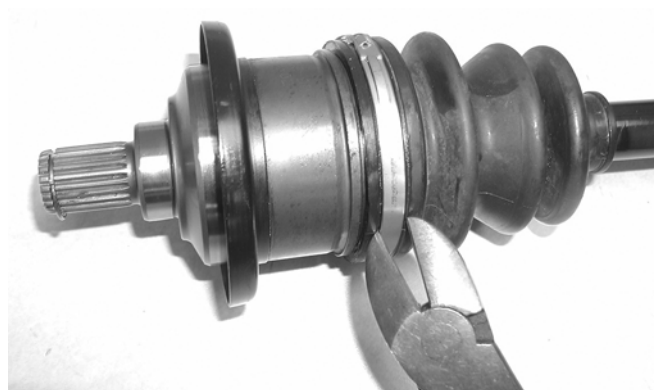

CD020

2. Wipe away excess grease to access the retaining ring. Using an awl or circlip pliers, remove the circlip.

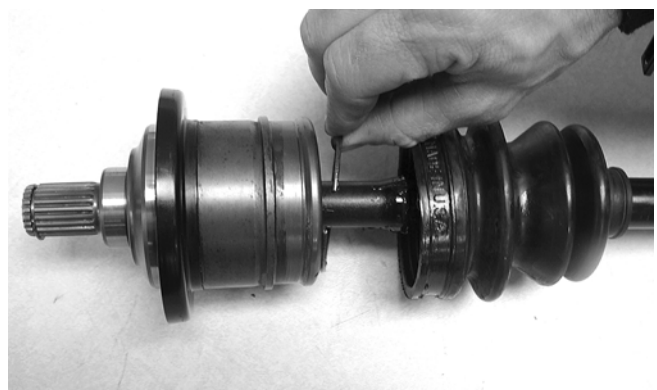

CD021

3. Using a snap ring pliers, remove the circlip securing the bearing ring to the shaft. Note the direction of the bearing for assembling purposes.

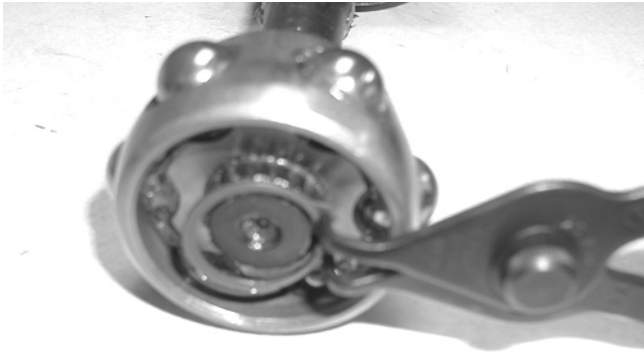

CD023

- Note the difference inside each bearing ring end for assembling purposes; then remove the bearing ring.

■ **NOTE:** The recess of the bearing must face toward the housing.



CD022

- Inspect the splines of the shaft, the bearing ring, and the housing for damage.

■ **NOTE:** If any damage is apparent to the splines, the bearing ring, and/or the housing, the drive axle must be replaced as an assembly.

- Using a side-cutters (or suitable substitute), remove the small clamp from the shaft.

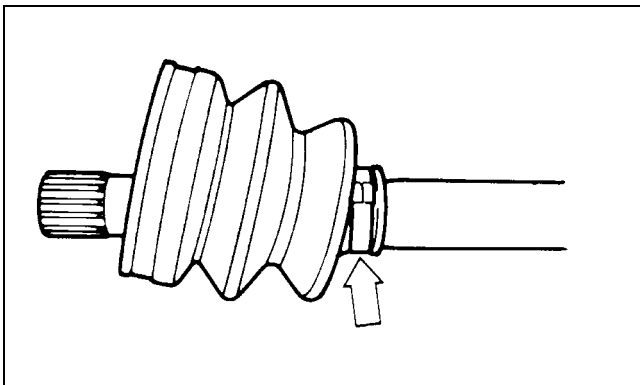

ATV-1048

■ **NOTE:** At this point if the outer boot is damaged, continue with step 7.

- Using a side-cutters (or suitable substitute), remove both outer boot clamps from the shaft. Note the position of the different-sized clamps for assembling purposes.



CD020

- Apply grease from the kit into the knuckles and the new outer boot.

■ **NOTE:** The large grease pack is for the inner drive axle bearing and boot assembly.

- Slide the new outer boot onto the shaft with the new clamps positioned as shown. Note the different-sized clamps from removal.

■ **NOTE:** The boot is positioned correctly when the small end of the boot seats down into the recessed groove.

- Using Boot Clamp Pliers (p/n 0444-120), secure both outer boot clamps.

CAUTION

It is important that the clamps are positioned correctly or they may loosen when in motion.



CD024

ASSEMBLING AXLES

- Install the inner boot with the small clamp making sure the ends of the clamp are positioned correctly.

■ **NOTE:** The boot is positioned correctly when the small end of the boot seats down into the recessed groove.

- Using the boot clamp pliers, secure the small clamp of the inner boot.

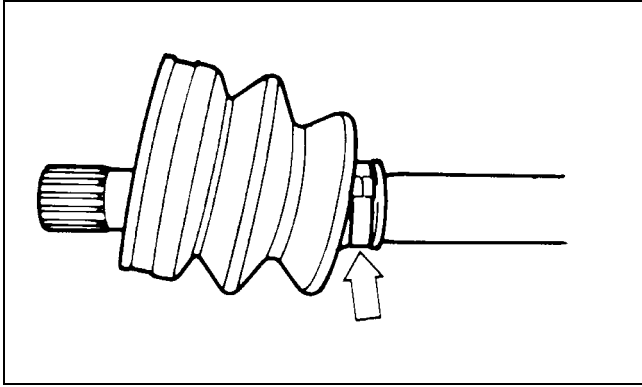

ATV-1048

- Apply grease from the kit onto the bearing ring making sure grease is on both the inner and outer sides; then apply the remainder of the grease into the housing and boot.

■ **NOTE:** The large grease pack is for the inner drive axle bearing and boot assembly.

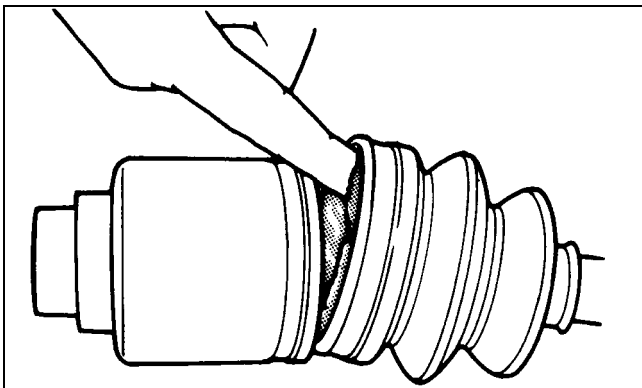

ATV-1052

- Install the bearing onto the shaft making sure the recess of the bearing is facing the housing.



CD022

CAUTION

The bearing ring must go onto the shaft with the side without splines facing toward the small clamp of the inner boot or severe damage will result.

- Secure the bearing ring with the circlip making sure the sharp side of the circlip faces away from the boot.

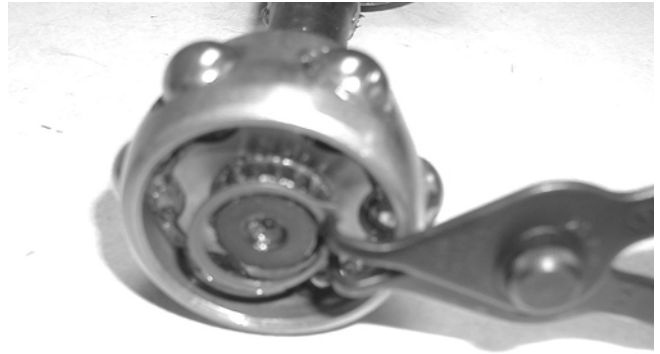

CD023

- Making sure the marks made during disassembling align, slide the housing over the bearing ring; then install the circlip.

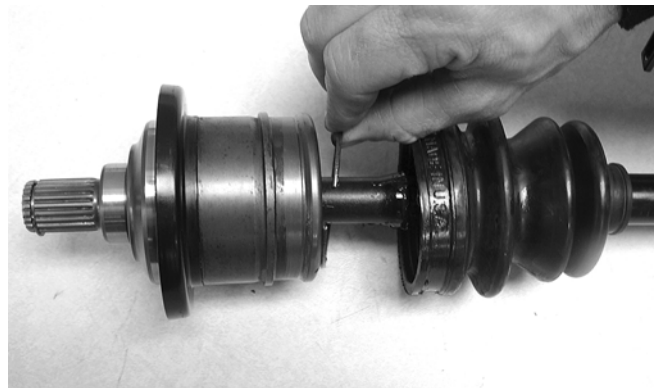

CD021

- Slide the boot over the housing; then using the boot clamp pliers, secure the boot with the clamp.



CD024

- Inspect the axle components for correct positioning of the four clamps. Also, inspect the boots for being correctly positioned on the shaft.

INSTALLING REAR DRIVE AXLE

- Apply Arctic Cat ATV High-Performance Grease (p/n 0436-501) to the splines; then slide the drive axle into place in the gear case.

■ **NOTE:** To assure proper seating of the axle, give it a light pull; the axle should remain “clipped” in place.

2. Swing the knuckle up and onto the drive axle; then place the knuckle into place in the upper A-arm. Secure the knuckle to the A-arm with a cap screw and a new lock nut. Tighten to 4.8 kg-m (35 ft-lb).
3. Place the hub into position on the axle followed by a washer and hex nut. Tighten the hex nut finger-tight at this time.
4. If the brake calipers were removed, position them on the knuckle and secure with existing cap screws. Tighten the auxiliary brake caliper cap screws to 2.1 kg-m (15 ft-lb). Tighten the hydraulic brake caliper cap screws to 2.8 kg-m (20 ft-lb).
5. Pump up the hand brake lever; then engage the brake lever lock.
6. Tighten the hub hex nut (from step 3) to 17.5 kg-m (125 ft-lb); then install and spread a new cotter pin making sure each side of the pin is flush to the hub nut.

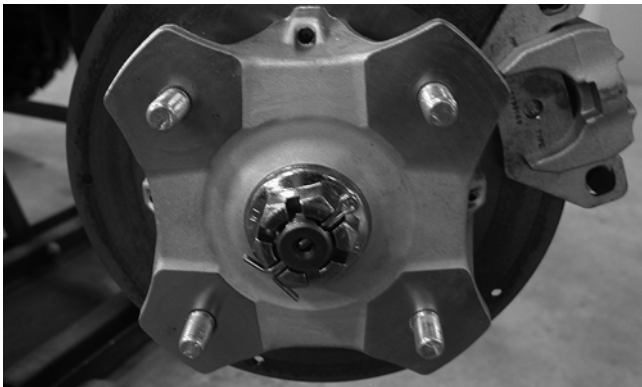

KX041

7. Install the wheel. Tighten to 5.5 kg-m (40 ft-lb).
8. Remove the ATV from the support stand and release the brake lever lock.
9. Check the engine/transmission oil level and add oil as necessary.

INSTALLING FRONT DRIVE AXLE

1. Position the drive axle in the gear case and steering knuckle; then insert the upper A-arm ball joint into the steering knuckle. Secure with a cap screw tightened to 4.8 kg-m (35 ft-lb).
2. Place the brake hose into position on the upper A-arm; then secure the lower shock eyelet to the A-arm with a cap screw and a new lock nut. Tighten to 4.8 kg-m (35 ft-lb).
3. Secure the tie rod to the steering knuckle with a new lock nut. Tighten securely; then install and spread a new cotter pin.

4. Slide the hub w/brake disc into position in the steering knuckle followed by a washer and hex nut. Tighten finger-tight at this time.
5. Install the brake caliper on the steering knuckle. Tighten to 2.8 kg-m (20 ft-lb); then pump up the hand brake lever and engage the brake lever lock.
6. Tighten the hub hex nut (from step 4) to 10.4 kg-m (75 ft-lb); then install and spread a new cotter pin making sure each side of the pin is flush to the hub nut.

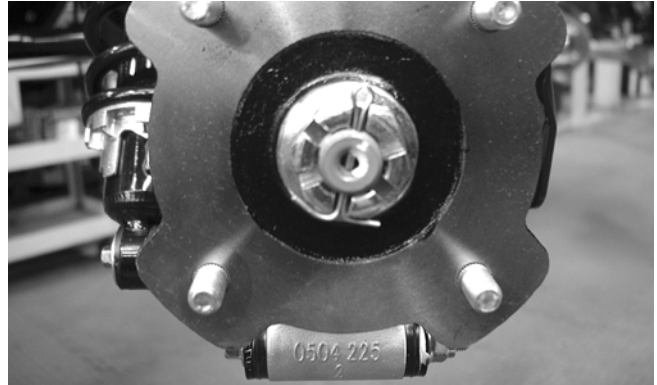

CD027

7. Install the wheel and tighten to 5.5 kg-m (40 ft-lb).
8. Remove the ATV from the support stand and release the brake lever lock.
9. Check the front differential oil level and add oil as necessary.

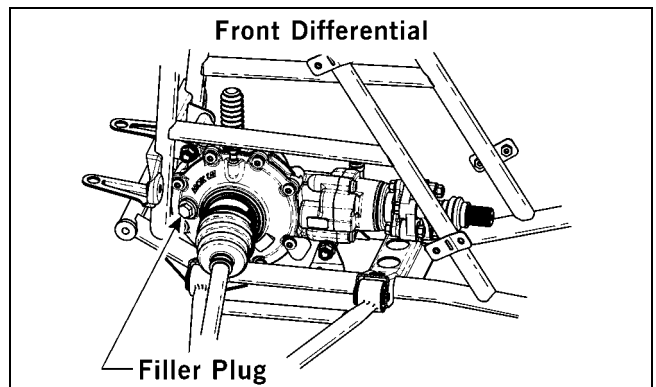

0736-568

6

Rear Gear Case

REMOVING

1. Remove the left-side rear A-arms (see Rear A-Arms in Section 7).
2. Remove both of the rear drive axles (see Drive Axles in this section).

- Remove the two cap screws and lock nuts securing the rear gear case to the frame; then move the gear case to the rear sufficiently to disengage the splined yoke from the rear output spline shaft. Remove through the left frame opening.



KX078

👉 AT THIS POINT

For servicing the input shaft, pinion gear, needle bearing, and axle seal, see Front Differential in this section.

INSTALLING

- Slide the gear case into position through the left side of the frame; then move the gear case to the rear sufficiently to engage the splined yoke with the splined rear output shaft.
- Position the gear case so the mounting cap screws can be installed; then with washers and new lock nuts, tighten to 4.3-5.3 kg-m (31-38 ft-lb).

■ **NOTE:** If a new gear housing is being installed, tighten the cap screws to 5.1-6.3 kg-m (37-45.5 ft-lb).

- Install the rear drive axles (see Drive Axles in this section).
- Install the left-side rear A-arms (see Rear A-Arms in Section 7).

Hub

■ **NOTE:** The hubs on this ATV have replaceable wheel studs. These studs are easily changed without removing the hub.

REPLACING WHEEL STUDS

- Support the ATV on adequate stands or a lift; then remove the applicable wheel.

- Thread a lug nut onto the stud; then using a hammer drive the stud out of the hub.

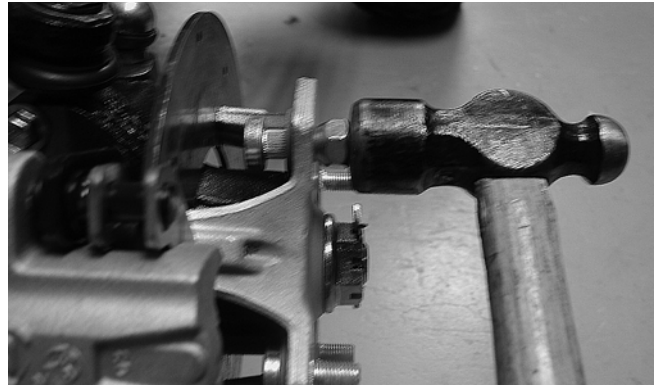

KX132

■ **NOTE:** If the threads are damaged, simply drive the stud out without threading on a nut.

⚠ WARNING

If any studs are loose in the hub, the hub must be replaced. Loose studs will not hold the wheel securely to the hub and hub breakage or wheel loss could occur causing loss of control, injury, or death.

- Insert a new stud in the hub; then install a lug nut with the flat side next to the hub and using an air wrench, draw the stud into the hub.

■ **NOTE:** Do not reuse wheel studs once removed.

REMOVING

- Secure the ATV on a support stand to elevate the wheel; then remove the wheel.

⚠ WARNING

Make sure the ATV is solidly supported on the support stand to avoid injury.

- Remove the cotter pin from the nut.

■ **NOTE:** During assembly, new cotter pins should be installed.

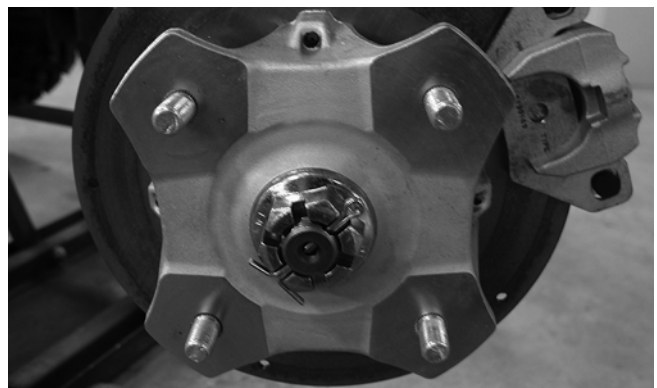

KX041

3. Remove the nut securing the hub. Account for a washer.

4. Remove the brake caliper.

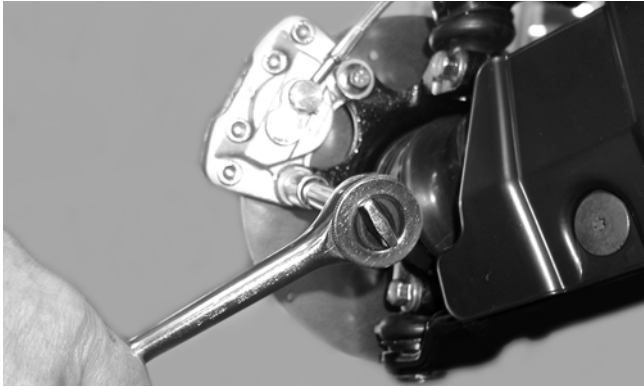

CD007

5. Remove the hub assembly.

6. Remove the four cap screws securing the brake disc.

CLEANING AND INSPECTING

■ **NOTE:** Whenever a part is worn excessively, cracked, or damaged in any way, replacement is necessary.

1. Clean all hub components.
2. Inspect all threads for stripping or damage.
3. Inspect the brake disc for cracks or warping.
4. Inspect the sealing area of the hub for pits.
5. Inspect the hub splines for signs of wear.
6. Inspect the hub for cracks.

INSTALLING

1. Secure the brake disc to the hub with the four cap screws coated with blue Loctite #243. Tighten to 2.1 kg-m (15 ft-lb).
2. Apply grease to hub sealing area and on the splines.

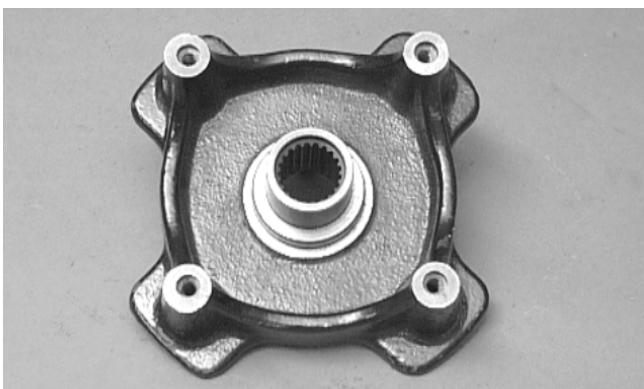

AF736D

3. Install the hub assembly onto the splines of the shaft.

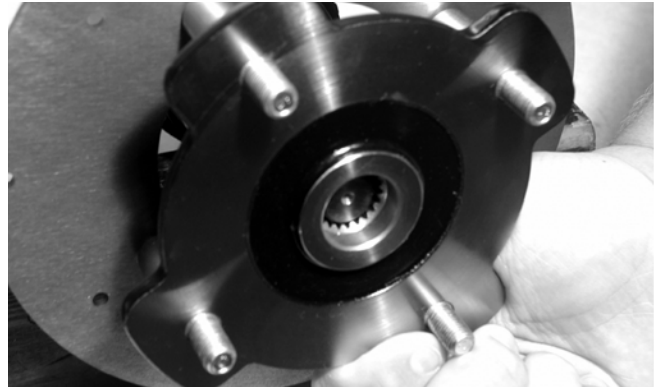

CD009

4. Insert the hub seal onto the shaft; then position it into the hub.

5. Place the washer onto the shaft; then secure the hub assembly with the nut. Tighten only until snug.

6. Secure the brake caliper to the knuckle with the two cap screws. Tighten the caliper to 2.8 kg-m (20 ft-lb).

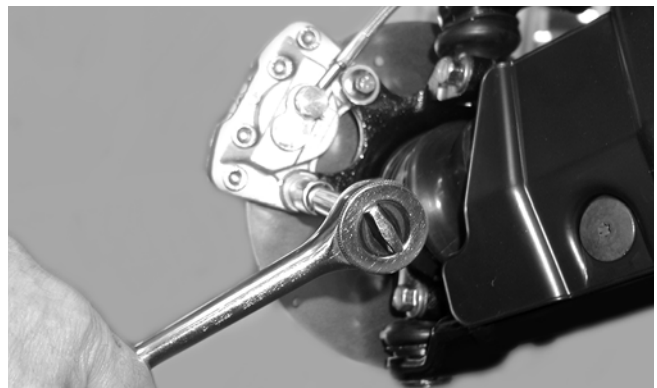

CD007

7. Tighten the hub nut (from step 5) to 10.4 kg-m (75 ft-lb) for the front or 17.5 kg-m (125 ft-lb) for the rear; then install and spread a new cotter pin making sure each side of the pin is flush to the hub nut.

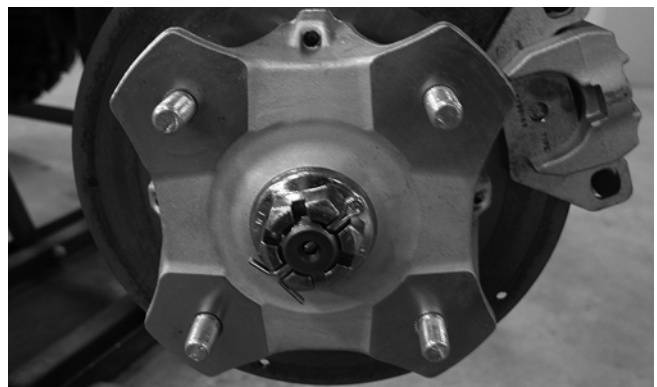

KX041

8. Install the wheel and tighten to 5.5 kg-m (40 ft-lb).



CD006

9. Remove the ATV from the support stand.

Hydraulic Brake Caliper

■ **NOTE:** The brake caliper is a non-serviceable component; it must be replaced as an assembly.

REMOVING/DISASSEMBLING

1. Secure the ATV on a support stand to elevate the wheel; then remove the wheel.

WARNING

Make sure the ATV is solidly supported on the support stand to avoid injury.

2. Drain the brake fluid from the entire hydraulic system (reservoir, hoses, and caliper).



AF637D

CAUTION

Brake fluid is highly corrosive. Do not spill brake fluid on any surface of the ATV and do not reuse brake fluid.

3. Remove the brake hose from the caliper; then remove the caliper.



AF636D

CLEANING AND INSPECTING

1. Clean all caliper components (except the brake pads) with parts-cleaning solvent.
2. Inspect the brake pads for damage and excessive wear.

■ **NOTE:** For measuring brake pads, see Section 2.

ASSEMBLING/INSTALLING

1. Push the pistons into the caliper as far as they will go to allow clearance for the brake pads.

CAUTION

Care should be taken that the piston and cylinder are not scratched.

2. Install the brake pads and secure with the pin and cotter pin.

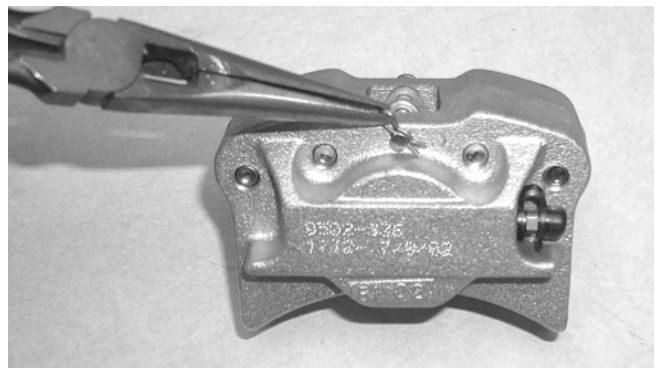

CD029

3. Place the brake caliper assembly into position and secure with the cap screws. Tighten the caliper to 2.8 kg-m (20 ft-lb).
4. Place a new crush washer on each side of the brake hose fitting and install it on the caliper. Tighten to 4.2 kg-m (30 ft-lb).
5. Fill the reservoir; then bleed the brake system (see Section 2).
6. Install the wheel. Tighten to 5.5 kg-m (40 ft-lb).



CD006

7. Remove the ATV from the support stand and verify brake operation.

Hydraulic Brake Assembly Schematic

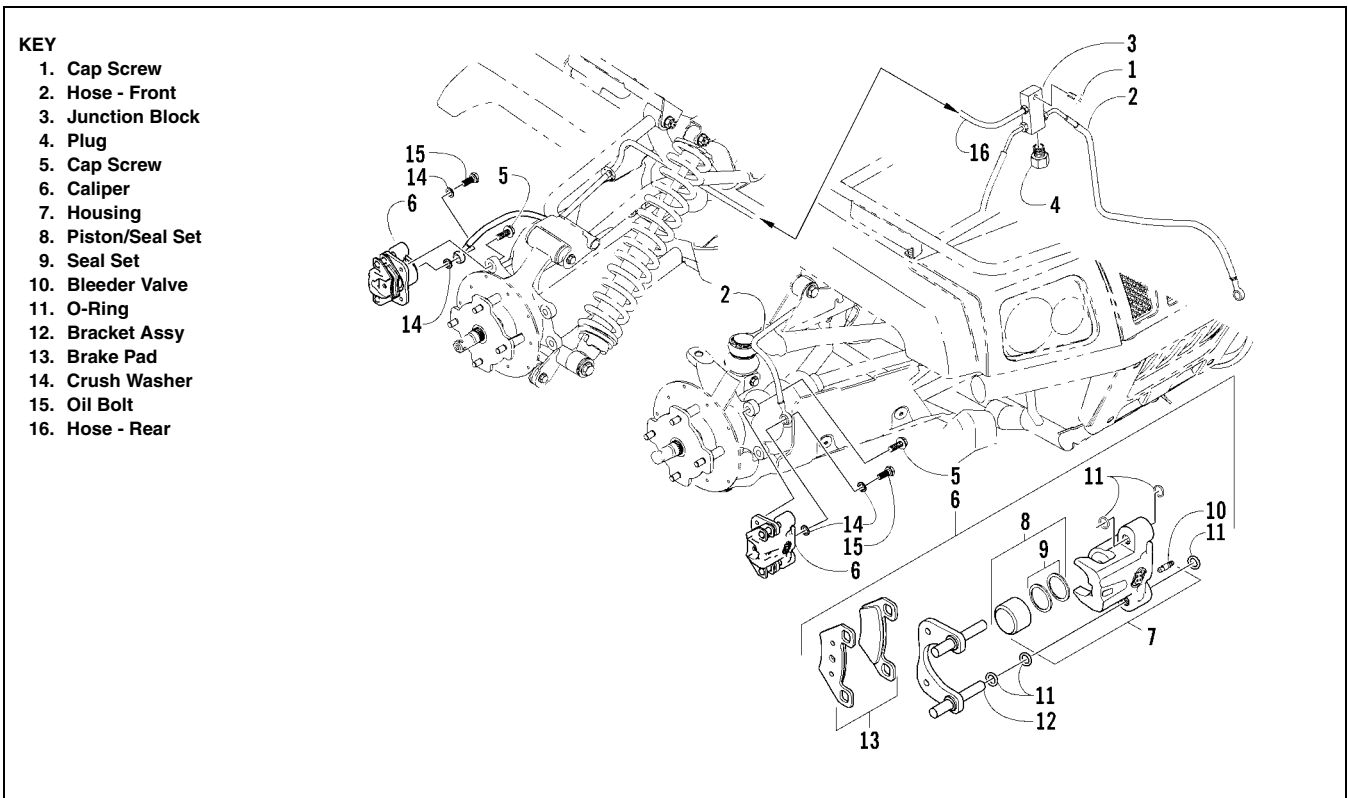

0739-253

6

NOTES